



Tohatsu's 9.9 hp EFI Sport received high honors for top speed, fuel consumption at idle and most importantly fuel efficiency at wide open throttle. The lightest weight outboard in its class features exceptional torque and top end speed so you can get where you need to go in a flash.



MFS9.9 specifications	
Number of Cylinders	2
Output	9.9 hp (7.3 kw)
Displacement	333 cc (20.32 cu.in)
Bore x Stroke	61 x 57 mm (2.40 x 2.24 in)
Starting	Electric or Manual
Control Type	Remote Control or Tiller Handle
Gear Shift	Forward - Neutral - Reverse
Gear Ratio	2.15:1
Propeller Selection Range	6" - 10"
Transom Height	15", 20", 25"
Weight	94.7 lbs (43 kg)
Alternator Output	Optional: 12V, 145W, 12A*
Max RPM Range	5,400 - 6,100
Power Tilt	Option
Standard features include: Digital CD Ignition System Start in Gear Protection, Thermostat Controlled Cooling System, Through-The-Prop Exhaust, Oil Pressure Warning, and Shallow Water Drive	
*Standard on Electric Start Models	



Feel the Wind™

MFS9.9

Dimensions

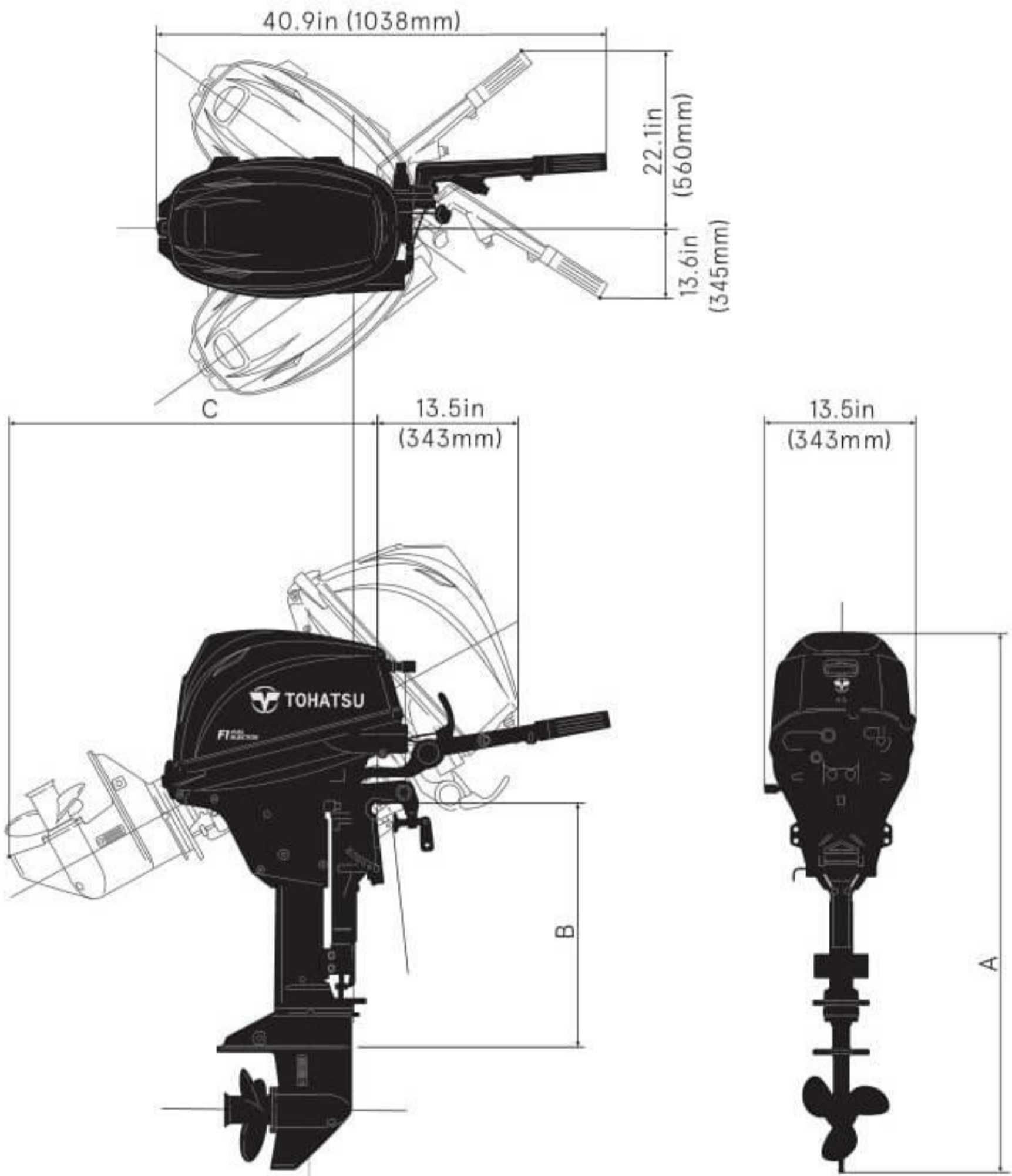

Dry Weight

(lbs/kg)

Model	MF	EF	EP	EFT	EPT
Transom S:	94.7 (43.0)	103.6 (47.0)	101.4 (46.0)	-	113.5 (51.5)
Transom L:	97.0 (44.0)	105.8 (48.0)	103.6 (47.0)	117.9 (53.5)	115.7 (52.5)
Transom UL:	-	-	-	121.2 (55.0)	119.0 (54.0)

Dimensions

(in/mm)

Model	A	B	C
Transom S:	43.9 (1116)	16.3 (413)	28.9 (735)
Transom L:	49.5 (1258)	22.1 (562)	34.3 (872)
Transom UL:	54.6 (1386)	27.1 (689)	38.9 (988)