



MFS3.5

MFS3.5 specifications

Number of Cylinders	1
Output	3.5 hp (2.6 kw)
Displacement	85.5 cc (5.2 cu.in)
Bore x Stroke	55 x 36 mm (2.17 x 1.42 in)
Starting	Manual
Control Type	Tiller Handle
Gear Shift	Forward - Neutral
Gear Ratio	2.15:1
Propeller Selection Range	4.5" - 7"
Transom Height	15", 20"
Fuel Tank	0.26 US Gal (1 Lit) Integral Tank
Weight	41 lbs (18.4 kg)
Max RPM Range	5,000 - 6,000

Standard features include: Digital CD Ignition System and Thermostat Controlled Cooling System

The Tohatsu MFS3.5 is lightweight and has a four point absorption system to minimize vibration. With the ergonomically designed front and back carrying handles and its sensational fuel economy, this compact 3.5hp engine has proven itself one of the best choices for portable outboard power. In addition, you can now store your engine in three different positions without worrying about oil spillage.



Feel the
Wind™

Dimensions

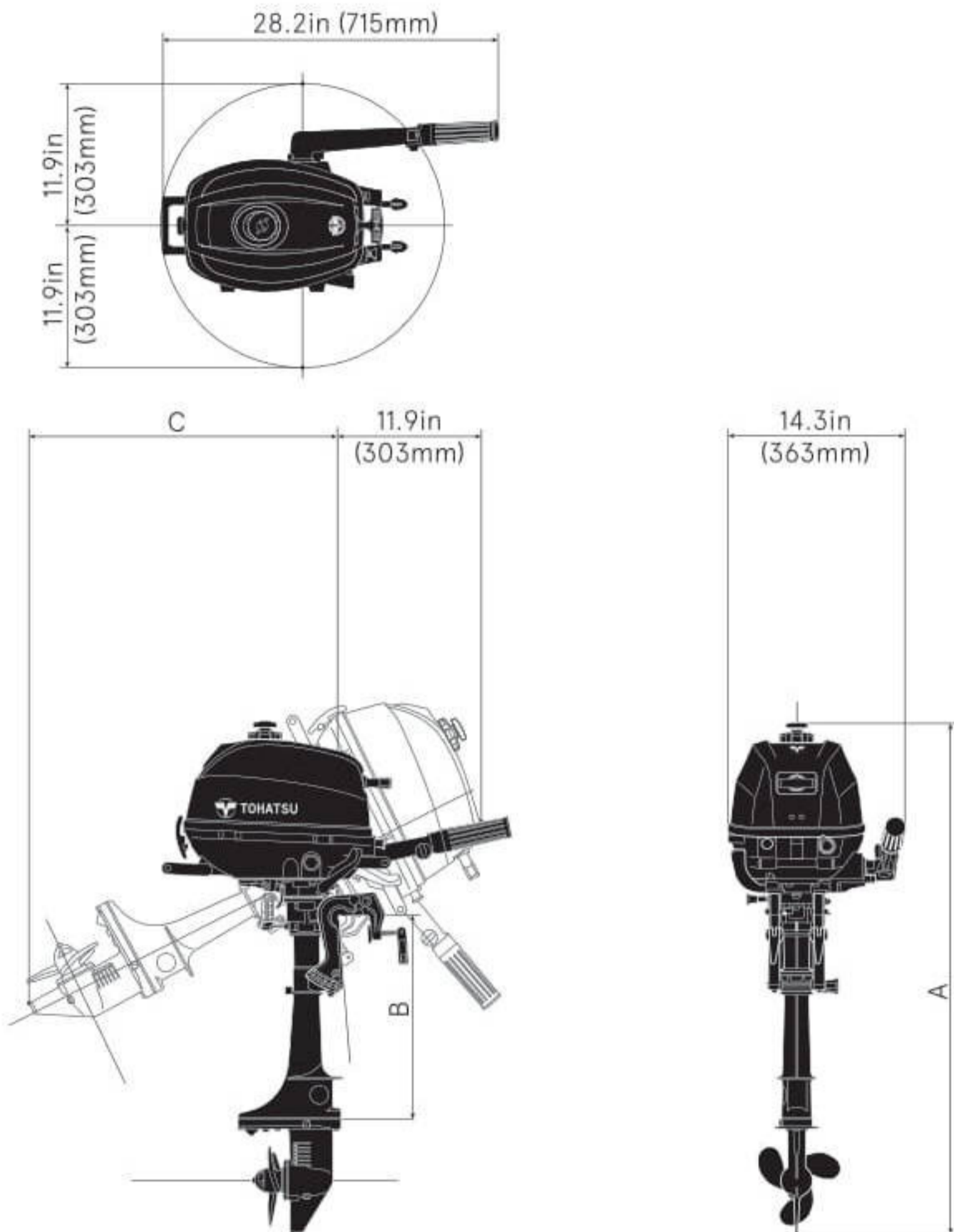

Dry Weight (lbs/kg)

Model	MF
Transom S:	41 (18.4)
Transom L:	43 (19.4)

Dimensions

(in/mm)

Model	A	B	C
Transom S:	40.4 (1026)	17.1 (435)	24.8 (628)
Transom L:	45.4 (1153)	22.1 (562)	28.7 (728)